

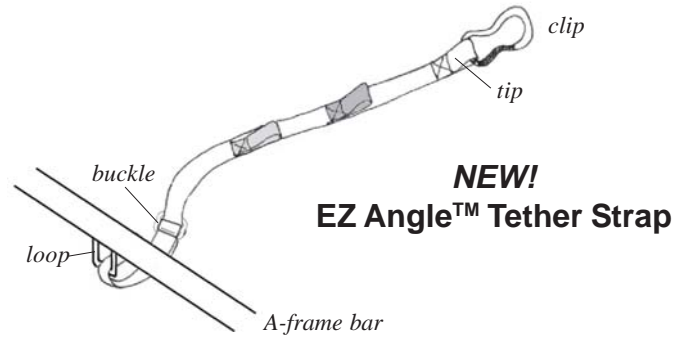

EZ Angle™ Tether Strap ASSEMBLY & USE INSTRUCTIONS

The EZ Angle™ Tether Strap is the newest upgrade to Teeter Hang Ups^a line of inversion tables. This convenient feature makes inverting even easier, offering pre-set angles to 20, 40 and 60 degrees.



Assembly:

(Only necessary if the tether strap is not pre-assembled.)

- ① Hold the tether strap upside down (so that the colored straps are facing the floor). Feed the tip of the strap through the designated loop on the a-frame (from back to front).
- ② Without pulling the strap entirely through the loop, insert the tip through the bottom opening of the buckle, and then again through the top opening.
- ③ Continue pulling on the tip of the strap until it is fitted snugly around the A-frame bar.
- ④ Attach the clip to the desired strap angle and hook the clip to the loop at the base of the table bed.

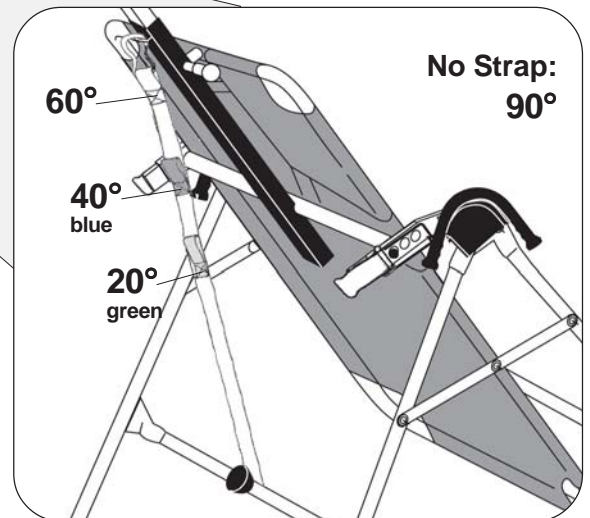

Easy-to-use:

- 20° - Secure the clip to the green strap for inversion to a gentle 20°.
- 40° - Secure the clip to the blue strap for inversion to a moderate 40°.
- 60° - Secure the clip to the tip of the strap for inversion to a more advanced 60°.
- 90° - Remove the tether strap entirely for full inversion, stretching and exercise!

USA & Canada:

STL International, Inc.
9902 162nd St. Ct. E.
Puyallup, WA 98375
Toll Free: (Phone) 800-847-0143; (Fax) 800-847-0188
Local: (Phone) 253-840-5252; (Fax) 253-840-5757
Info@STLIntl.com www.STLIntl.com

International:

Inversion International, Ltd.
PO Box: AP 59245
New Providence Island, Bahamas
(Phone) +1-242-362-1001; (Fax) +1-242-362-1002
(email) Info@InversionInternational.com
(web) www.InversionInternational.com

Europe:

Teeter Ltd.
Cygnet House, Sydenham Road
Croydon, Surrey CR0 2EE, United Kingdom
(Phone) +44-20-8667-0060
(Fax) +44-20-8680-3999
(email) mail@TeeterLtd.com
(web) www.TeeterLtd.com